

## Partner Company Position Dataform

Company name	Kolo Tech
Position title	Welder
Number of Employees to be hired	15
Required educational background	Qualification in welding
Expected professional experience	Politechnic student is okay as well/fresh graduated
Expectations about language skills	1-2 candidates with good English, for the rest basic English skills (request: being able to introduce themselves in a few sentences, able to answer the questions)
Please explain the job description and the workflow. What type of machines are used at the Company? Please describe it!	<ul style="list-style-type: none"> <li>• Stays in constant contact with other employee and with his supervisor</li> <li>• Carries out the correct condition, starting and stopping of the equipment (welding machine, lifting crane) in the work area and the movement of the finished workpieces</li> <li>• Handles the work equipment necessary for the work, moves boiler elements and boiler bodies in accordance with the work process in accordance with the professional requirements, the equipment operating instructions, the technological instructions and other regulations</li> <li>• It assembles the boiler bodies which, depending on the type, are either prepared for robot welding or welded ready</li> <li>• Picking out non-conforming products and collecting and repairing them at the designated place</li> <li>• Check the condition of the equipment before loading with a crane and take the necessary safety measures</li> <li>• In all cases, the boilers are lifted in accordance with the lifting plan so that no tilting or tipping due to any reason during their movement</li> <li>• in case of any problem he stops the device he is using</li> <li>• Prevents simple errors that occur during operation</li> <li>• Keep machines and equipment clean, clean up the work area and carry out daily maintenance tasks</li> <li>• After the work is completed, the machines and equipment are disconnected from the power supply</li> <li>• must notify or inform the manager or his/her supervisor of any obstacles, non-conformities which he/she cannot overcome, hazards or emergencies</li> <li>• Carry out other duties as assigned by your superior</li> <li>• The job description includes the full performance of the tasks specified in the ISO quality management system documentation</li> </ul> <p><b>Pressure Test - to check air tightness MAG welding technology</b></p>

Expectations related to the characteristics of Employee's personality	
Physical characteristics requirements (if any), e.g., height minimum or being able to move certain heavy objects	Non-injured hands, good physical condition
Further requirements to be considered during the selection	No criminal record
Planned entry date	June 2023
Duration of the fixed term employment contract	2 year
Probation period	3 months
Work schedule	4+4 working schedule, 12-hour shift: from 6 am to 6 pm OR from 6 pm to 6 am
Technology used in the Company (description or photos)	
Place of employment	Mezőberény 5650
Employee's net monthly salary (numeric data only, basic salary without any extra benefit or allowance)	Net: 234.080,- Ft (657 USD) under 25 years old: 286.880,- Ft (805 USD)
Overtime opportunities	Available
Overtime compensation	According to Hungarian law
Hereby acknowledged that accomodation has to be provided by the hosting Company. (YES)	YES
Hereby acknowledged that daily commuting and visa administration expenses and the cost of a flight from Jakarta to Budapest have to be covered by the hosting Company as part of the program. (YES)	YES
Opportunity for professional development; if exists, for what position?	Available, there is an opportunity to change to fitter position
Work clothes (with size chart)	Provided
Transportation between workplace and accomodation	Provided for those who are not accommodated locally
Worship place (small, carpeted, clean and empty room, with hand and foot washing facilities nearby)	YES
Additional information	Accomodation is nearby to the company, 500m by walk Facility: WiFi, TV, Fridge, AC

### Partner Company Position Dataform

Company name	<b>Kolo Tech</b>
Position title	<b>Fitter</b>
Number of Employees to be hired	<b>5</b>
Required educational background	Technical or professional qualifications Experience, basic language skills

## OPEN POSITION

Expected professional experience	Politechnic student is okay as well/fresh graduated
Expectations about language skills	1-2 candidates with good English, for the rest basic English skills (request: being able to introduce themselves in a few sentences, able to answer the questions)
Please explain the job description and the workflow. What type of machines are used at the Company? Please describe it!	<p>Forming, assembling of stoves and other heating equipment and also its components Pressure test - to check air tightness</p> <ul style="list-style-type: none"> <li>• Checks the working conditions wheter is safe or not.</li> <li>• Ensuring the continuous and safe operation of the process line from a mechanical point of view.</li> <li>• Maintains, repairs, assembles and reconditions the machinery and equipment required for boiler production.</li> <li>• Elimination of fitter and mechanical defects.</li> <li>• Define the list of materials needed for the overhaul.</li> <li>• Carry out the necessary preparatory tasks when changing products.</li> <li>• Performs any production task in the boiler manufacturing process at the direction of his/her supervisor. These are the assembly of boiler bodies (spot welding), preparation for robotic welding, finishing welding of boiler bodies, handling of robotic welders if necessary.</li> <li>• Check the conformity of the boiler bodies by visual inspection and pressure test (wet or air). Separate and repair non-conforming boiler bodies.</li> <li>• Carrying out the mechanical adjustments and modifications required in the technological line according to the instructions of the supervisor.</li> <li>• Document maintenance and repairs carried out on the process line on the equipment registry sheet</li> <li>• May operate electric arc or flame cutting equipment, welding machines, laser cutting machines</li> <li>• Ensure the availability of spare parts.</li> <li>• Carry out other duties as assigned by your superior</li> <li>• Fully perform the tasks specified in the ISO quality management system documentation</li> </ul>
Expectations related to the characteristics of Employee's personality	
Physical characteristics requirements (if any), e.g., height minimum or being able to move certain heavy objects	Non-injured hands, good physical condition
Further requirements to be considered during the selection	No criminal record
Planned entry date	June 2023

## OPEN POSITION

Duration of the fixed term employment contract	2 year
Probation period	3 months
Work schedule	4+4 working schedule, 12-hour shift: from 6 am to 6 pm OR from 6 pm to 6 am
Technology used in the Company (description or photos)	
Place of employment	Mezőberény 5650
Employee's net monthly salary (numeric data only, basic salary without any extra benefit or allowance)	Net: 234.080,- Ft (657 USD) under 25 years old: 286.880,- Ft (805 USD)
Overtime opportunities	Available
Overtime compensation	According to Hungarian law
Hereby acknowledged that accomodation has to be provided by the hosting Company. (YES)	YES
Hereby acknowledged that daily commuting and visa administration expenses and the cost of a flight from Jakarta to Budapest have to be covered by the hosting Company as part of the program. (YES)	YES
Opportunity for professional development; if exists, for what position?	Available
Work clothes (with size chart)	Provided
Transportation between workplace and accomodation	Provided for those who are not accommodated locally
Worship place (small, carpeted, clean and empty room, with hand and foot washing facilities nearby)	YES
Additional information	Accomodation is nearby to the company, 500m by walk Facility: WiFi, TV, Fridge, AC

# OPEN POSITION

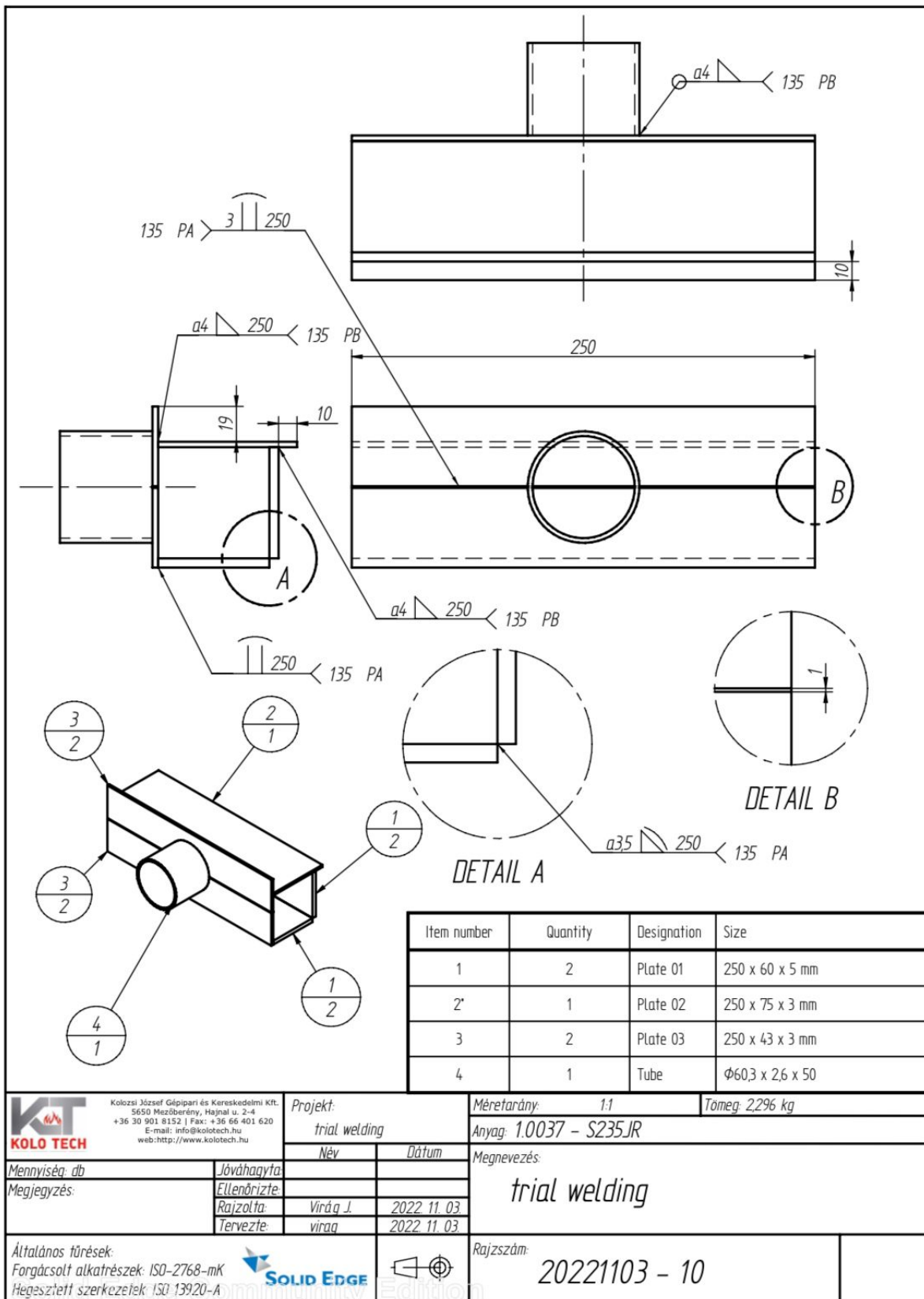

## WPS Welding Practical Test